

Blaenau Gwent County Borough Council  
Cyngor Bwrdeisdref Sirol Blaenau Gwent

# SPG Householder Design Guidance

February 2016



**1. Contents and Preface**

**2. Introduction**

**3. section 1: preparing your design**

- Step 1: Consider professional design advice
- Step 2: Speak to your neighbours
- Step 3: Speak to the Local Planning Authority
- Step 4: Follow the design guidance

**7. section 2: submitting your application**

- Submitting your application
- Typical requirements for submitting a planning application
- Contacts
- Further reading

**section 3: guidance on design**

- Guidance Note 1: Extensions and conservatories
- Guidance Note 2: Garages and outbuildings
- Guidance Note 3: Dormer windows and rooflights
- Guidance Note 4: Boundary treatments
- Guidance Note 5: Trees and other vegetation
- Guidance Note 6: Providing for access and parking
- Guidance Note 7: Raised decks, retaining walls and balconies
- Guidance Note 8: Resource efficiency
- Guidance Note 9: Crime prevention

**preface**

This guide was originally produced as an all-Wales guide by the Planning Officers Society for Wales (POSW), in conjunction with the Welsh Government (WG), under the title 'A Design Guide for Householder Development'. It has since been amended to meet the needs and local challenges of Blaenau Gwent.

The main purpose of this document is to improve the standard of design of householder development in the Borough. It will provide the Council with a sound basis for managing the design and development process. It also gives developers some certainty that the design objectives they are working to are the same as those expected by and acceptable to the Council.

It is the intention of this document to ensure that new development makes a positive contribution to creating and maintaining sustainable and attractive communities throughout the Borough.

In order for the guide to be a useful and effective management tool, the Design Guide has been adopted as Supplementary Planning Guidance to policies:

- DM1 New Development; and
- DM2 Design and Placemaking

of the Blaenau Gwent Local Development Plan (2012). Other policies in the Local Development Plan may also be relevant to some developments.

**This guide will be a major consideration in the determination of householder planning applications.**

It should be noted that this document does not specifically consider flats and maisonettes. Whilst some of the principles

of this document would apply, details such as permitted development rights do not. Flats and maisonettes do not enjoy the same permitted development rights as individual dwellings.

## introduction

National planning policy for Wales requires that all new development, extensions and alterations to existing properties are well designed.

Well designed and built alterations and extensions can help homeowners meet their changing needs, add value to their property and enhance the local area. With good design, it is also possible to reduce energy bills and avoid wastage of natural resources.

However, badly designed alterations and extensions can spoil the appearance of a building and have a negative impact upon surrounding streetscapes and landscapes, as well as the living conditions of neighbours.



## How to use this Design Guide

The document is split into three sections. When using the guide you should first read **Section 1** which provides advice on the steps to follow when preparing your design:

**Step 1:** Consider professional design advice

**Step 2:** Speak to your neighbours

**Step 3:** Speak to the Local Planning Authority

**Step 4:** Follow the relevant design guidance notes

**Section 2** sets out the information you will need to submit with your planning application.

**Section 3** of the document includes a series of guidance notes. You will need to read Guidance Note 1 and any others you consider relevant to your proposal.

- 1: Extensions and conservatories
- 2: Garages and outbuildings
- 3: Dormer windows and rooflights
- 4: Boundary treatments
- 5: Trees and other vegetation
- 6: Providing for access and parking
- 7: Raised decks and balconies
- 8: Resource efficiency
- 9: Crime prevention



# preparing your design

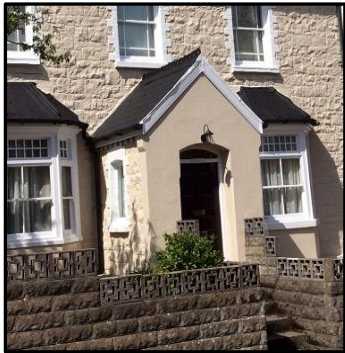

**Achieving good design need not be difficult, by following the next 4 steps you will address the most important design issues before you submit your planning application**

## Step 1

### Consider professional design advice

A professional advisor can help you prepare plans that meet the Council's requirements. Visiting a professional advisor is likely to save you time and cost as they will be familiar with the requirements of the Council. A professional consultant is likely to submit the application and liaise with the council on your behalf. This can speed up the process and result in development that looks better, adds value to your home and has a better chance of success.

You may know someone who has carried out similar work and may be able to recommend someone locally to assist you. It is a good idea to obtain references from previous clients if possible. Architects and Designers often advertise on line and in the local papers. **Please note that the Council cannot recommend an architect, Designer or agent to you.**

**Finding professional advice:** The Royal Society of Architects Wales (RSAW) provides guidance on selecting and appointing an architect. In addition the Royal Town Planning Institute, (RTPI), The Royal Institution of Chartered Surveyors (RICS) and the Chartered Institute of Architectural Technologists (CIAT), Architects Registration Board, Landscape Institute, Planning Portal Wales, Local Architects Direct, Planning Aid Wales can also provide advice. **A list of professional organisations is available under Useful Contacts at the end of at the end of Section 2.**



**Preparing a brief:** An important part of your brief should be to meet the requirements of this guide. It is in your interest to write down your design requirements and how much you want to spend as a brief to the designer. You will need to ensure that terms of engagement and the scope of the works is agreed in writing and understood fully by all parties. You are advised to ensure that the professional commissioned holds professional indemnity insurance.

## Step 2

### Speak to your neighbours

Let your neighbours know about work you intend to carry out to your property. They are likely to be as concerned about work which might affect them as you would be about changes which might affect your enjoyment of your own property. Whilst there is no "right to light" under planning if the work you carry out overshadows a neighbour's window or garden and that window has been there for 20 years or more, you may be affecting his or her "right to light" and you could be open to private legal action – in such cases you should obtain legal advice.

You may be able to meet some of your neighbour's worries by altering your proposals. Even if you decide not to change what you want to do, it is usually better to have told your neighbours what you are proposing before you apply for planning permission or before building work starts.

If you do need to make a planning application for the work you want to carry out, the Council will ask your neighbours for their views. If you or any of the people you are employing to do the work need to go on to a neighbour's property, you will, of course, need to obtain his or her consent before doing so.

## Step 3

### Speak to the Local Planning Authority

For a set fee, the Development Management Team will be able to provide you with planning advice before you submit your planning application. The advice given will enable and encourage quality schemes whether it is an extension, garage or other minor development. They will be able to advise on whether you need planning permission or not, and whether other consents such as Listed Building Consent are also required. Planning advice procedure and charges are available via the link below;

<http://www.blaenaugwent.gov.uk/documents/DocumentsEnvironment/PAN6PrelimCharging.pdf>

### Permitted Development

Some minor changes to your house and small buildings in your garden may not need planning permission and are known as 'permitted development'. The following is a list of examples of Permitted Developments:

- Certain enlargements or alterations to houses.
- Provision of certain pet enclosures, sheds and fuel storage containers.
- Certain porches, doors and windows.
- Installation of antenna and satellite dishes.
- Certain gates, fences, walls and other enclosures.
- The provision of certain hard surfaces and means of access to a highway.
- Installation and alterations to certain chimneys.
- The installation of cctv for security purposes.
- Exterior painting (other than advertisements).
- Internal alterations.

- Certain micro generation equipment.
- Building operations consisting of the demolition of a building

However, you are advised to check with the Local Planning Authority to confirm if your development is classed as Permitted Development. How to obtain this advice and the fees involved are available via the link below:

<http://www.blaenau-gwent.gov.uk/documents/Environment/PAN6PrelimCharging.pdf>

When you have decided what works are required, you should use this guide to assess whether your proposal would comply with this good practice design guidance. Another useful tool that could assist you is the Planning Portal (details under useful contacts).

Advice on typical drawing requirements, are given in **Section 2** of this document. You can also check with the Development Management Team what forms and supporting documents they will require with your application. Submitting incomplete or inadequate drawings will delay registration of your planning application.

## What other permissions do I need?

**Party Wall Act:** The Party Wall etc. Act 1996 provides a framework for preventing and resolving disputes in relation to party walls, boundary walls and excavations near neighbouring buildings. The Act is separate from obtaining planning permission or building regulations approval. Information can be found via the link below:

<http://www.planningportal.gov.uk/buildingregulations/buildingpolicyan/legislation/currentlegislation/partywallact>

**Listed Buildings:** If your property has special historic or architectural character it may be a Listed Building which gives

it special protection under planning laws. This means that before undertaking any alteration works that affects the setting of the building, such as boundaries, extensions, demolition and any other work that affects the character of the Listed Building (both externally and internally), you will need to get Listed Building Consent from the Council. This will be in addition to planning permission. Please contact the Heritage Officer (01495 353313) for further information.

**Conservation Areas:** If your property is within Tredegar Conservation Area, your permitted development rights are more restricted. Even some alterations to the exterior of a property such as cladding of any part of a house, whether it be the original house or any enlargement, with stone, artificial stone, pebble dash, render, exterior wall insulation, timber, plastic, metal or tiles may require planning permission. There are also controls over trees and demolition in conservation areas. Please contact the Development Management Officer (01495 355318) for further information.

**Tree Preservation Orders:** Some trees which are important to the local area are protected by Tree Preservation Orders (TPO) issued by the Council. If your development affects a tree that is covered by a TPO you will need permission before carrying out works. Please contact the Green Infrastructure Team (01495 311556) for further information.

**Building Regulations:** All works (with exception of some garages and conservatories) must comply with Building Regulations and must be approved for compliance with these regulations by the Building Control Team. Please contact the Building Control Team (01495 355521) for further information.

**Protected Species:** Some buildings or gardens may be occupied by species which are protected by law, those species which are most commonly encountered within Blaenau Gwent are bats, breeding birds and reptiles (most notably slow worms and common lizard) but it is possible that other less common protected species may also be present. It may be that extra surveys are needed to find out what is on the land or within the building or that some of the works will require sensitive timing (such as outside the bird nesting period). Some works may also need to be licensed, such as disturbing or removing a bat roost and Natural Resources Wales will need to be consulted for this type of work. If you think your property or land could be home to a protected species you should first contact the Council Ecologist (01495 311556) to get their advice on how to proceed with any proposed development.

**Flood Risk:** In areas at risk of flooding, we recommend that consideration be given to the incorporation of flood resistance/resilience measures into the design and construction of the development. These could include flood barriers on ground floor doors, windows and access points, implementation of suitable flood proofing measures to the internal fabric of the ground floor, and locating electrical sockets/components at a higher level above possible flood levels.

Additional guidance including the leaflet; 'Prepare your Property for Flooding' can be found at: [www.environment-agency.gov.uk/homeandleisure/floods/31644.aspx](http://www.environment-agency.gov.uk/homeandleisure/floods/31644.aspx)

If you carry out any work including building an extension or making alterations that need planning permission or another form of consent without first obtaining the necessary permissions, you may be subject to Enforcement Action and prosecution in the Courts. You may also have to put things right later at considerable inconvenience and cost.

Finally please be aware that the rules governing what requires planning permission change on a regular basis. Most householder rules changed significantly in August 2013 and continue to be revised by Welsh Government. You are advised to check this with the Local Planning Authority or your agent before proceeding.

## Step 4

### Follow the design guidance

#### Understanding Your House and Area

When first considering making an application for a new extension or alterations to your property, you will need to assess your house and garden and the contribution they make to the area. It is important that any alterations are sensitively designed to fit in with the wider street scene. Think about the house types in the vicinity. Consider whether the properties in your street have a variety of building design and form or whether they have a strong consistent character such as a certain height, building form or design feature which will need to be incorporated into your own proposed development. Consider whether the changes you propose to your property are likely to enhance the street scene or detract from it.

In some circumstances high quality contemporary approaches can positively contribute to a locality. However, simple contemporary design requires an attention to detail to achieve a high quality finish. Therefore more detailed drawings would be required to adequately assess the proposal.

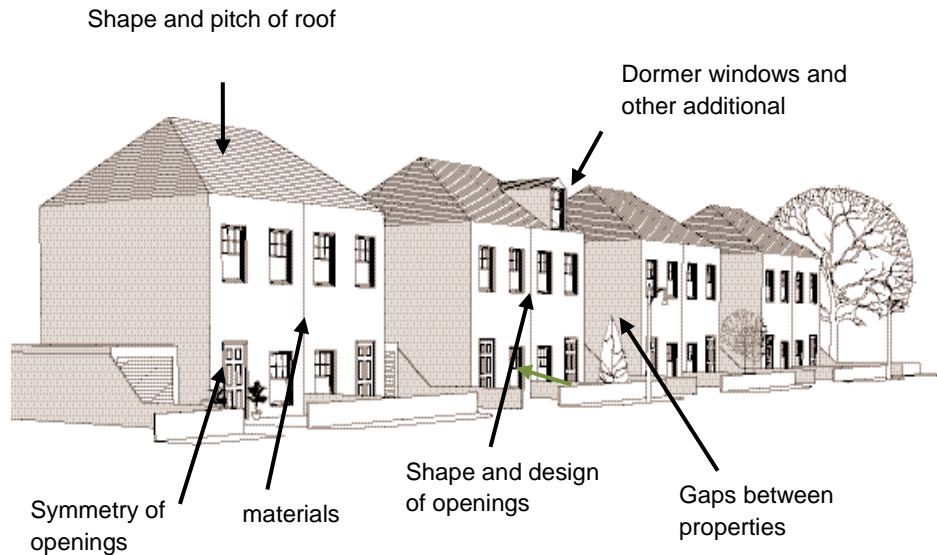

frontage of a typical street with semi-detached houses

### Key Considerations:

- **House type** - is your house terraced, detached or semi-detached. Is it three storey, two storey or a bungalow?
- **Architectural period** - is your house of a certain architectural period, for example: terraced house, 1930/1950 style semi-detached or a 1970 dormer bungalow?
- **Roof** - what shape roof does it have, for example is it hipped, pitched, mono-pitched or flat?
- **Distinctive features** - does your house have any distinctive features such as dormer extensions, chimneys, extensions or conservatory or decorative features.
- **Windows and doors** - Do you have a modern/contemporary home with modern horizontal style windows or a more traditional cottage/terraced style home

with traditional sash style windows; look to your home's architectural style for guidance.

- **Materials** - what materials have been used to build your home for example stone or brick walls, wood or upvc windows and doors, slate or tiled roof.
- **Car parking** - what is the parking situation in the area?

In addition to the design and siting of your own property you must also consider key characteristics of your immediate neighbouring properties.

Extensions, outbuildings or other forms of householder development must be considered with regards to size, position design, scale and massing in order to avoid **overlooking, overbearing** and **overshadowing**. You can avoid these issues by:

- Observing the distance between your own and your neighbour's property, in particular to garden areas and windows.
- Considering the difference in ground level, if it's higher than your neighbours extra care will be needed.
- Considering whether your proposed development will have a direct impact on the natural sunlight enjoyed by your neighbours.

Please be aware that just because a neighbour has a large extension, it does not necessarily follow that you should be allowed the same. Each application will be determined on its merits with reference to the design guidance and policy framework relevant at the time. When preparing proposals key issues to consider are:-

- **Height** - The height of other buildings will likely limit the height of new development or extensions.



# Section 1

- **Building line** - Ensure that your development respects the line which has been created by existing properties. Development such as long rear extension which project significantly beyond the established building line may be refused.
- **Spacing** - Spaces between buildings often contribute to the street scene. There is usually a consistent sized gap between buildings on streets where semi-detached dwellings dominate the style of dwelling. If this feature is consistent along the street scene then it should not be compromised.

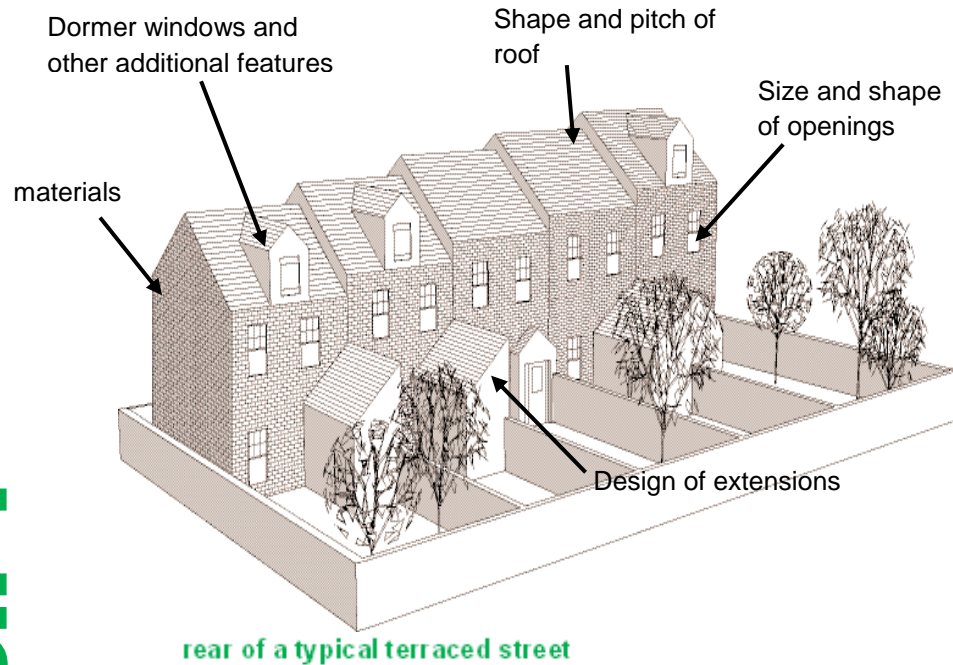

- **Front boundaries** - Where they exist, front boundaries help to distinguish between public and private areas and can present an important and unifying design feature within the street scene. Front boundaries must not obstruct views of the house from the street, or of the street from the house, for reasons of aesthetics, security and highway safety
- **Mature trees, hedges and other planting** - Existing natural vegetation can contribute significantly to the setting of a house and attractiveness of the street scene.
- **What makes your home and street feel safe?** - Think about what qualities of your home and street make you, other residents and pedestrians feel safe and how this can be preserved or enhanced.

## Follow the design guidance notes

You should follow the relevant guidance set out in **Section 3** of this guide to help you achieve a good design. The Council will check if your plans follow this guidance. If they do not you are more likely to incur delays from having to amend your proposal and/or having your proposal refused planning permission.

# submitting your application



**This section outlines what information must accompany all householder planning applications and what additional information would help the Council in its consideration of the application**

There are legal requirements for submitting a planning application. The Council, your neighbours and anyone else we consult must be clear exactly what you want to build. This is essential to be able to properly assess the impact of your proposal on your property, your neighbour's property and the surrounding area. It is also important to be able to check afterwards that what you build is what you had permission for.

The following outlines what will be required. Separate guidance notes are sent out with all planning application forms to explain the information required.

## **Forms**

You will require a Householder form. This is available on the website along with a guidance note to help fill it in.

**You can submit your application in a variety of ways:**

### **electronically via:**

Planning Portal:-

<https://www.planningportal.gov.uk/permission/>

### **via email at:**

[planning@blaenau-gwent.gov.uk](mailto:planning@blaenau-gwent.gov.uk)

### **by hand or post to:**

Planning Dept  
Civic Centre  
Ebbw Vale  
NP236XB

## Typical requirements for a planning application

There are standard requirements for submitting a planning application and you should check what drawings, plans and illustrations you will need. Typical requirements are set out in this section.

### Location plan

- Scale 1:1250 preferably and no smaller than 1:2500
- Include a North point
- Outline the application site in red, and indicate any adjoining land owned or controlled by the applicant with a blue line
- Show the application property in relation to all adjoining properties and the immediate surrounding area, including roads
- Show vehicular access to a highway if the site does not adjoin a highway

### Details of existing site layout - block plan

- Scale, typically 1:200 or appropriate scale to ascertain required level of detail
- North point, date and number on plans
- Show the whole property, including all buildings, gardens, open spaces and car parking
- Existing features on the site, e.g. trees, walls, watercourses, drainage and other natural features
- Existing services such as drains, gas mains
- Indicate all boundaries and the position of nearest buildings

### Details of proposed site layout

- Scale, typically 1:200
- North point, date and drawing number on plans
- Show the siting of any new building or extension, vehicular/pedestrian access, changes in levels, landscape proposals, including trees and hedges to be removed and retained, new planting, new or altered boundary walls and fences, and new hard-surfaced open spaces
- Show proposals in the context of adjacent buildings, watercourses, drainage and other natural features.

### Floor plans

- Scale 1:50 or 1:100
- In the case of an extension, show the floor layout of the existing and proposed building to indicate the relationship between the two, clearly indicating new work.
- Indicate the proposed finished floor levels (wherever possible).
- Show floor plans in the context of adjacent buildings, where appropriate
- In the case of minor applications it may be appropriate to combine the site layout and floor plan (unless any demolition is involved)
- Include a roof plan where necessary to show a complex roof or alteration to one

### Elevations

- Scale 1:50 or 1:100 (consistent with floor plans)
- Show every elevation of a new building or extension
- For an extension or alteration, clearly distinguish existing and proposed elevations
- Include details of material and external appearance

- Show elevations in the context of adjacent buildings, where appropriate

## Cross sections

- Scale 1:50 / 1:100 (consistent with floor plans), where appropriate

## Also Required

- Fees
- Land Ownership certificates
- Structural calculations and design certificates for retaining walls over 1.5 m

## Useful contacts

### Blaenau Gwent Council contacts

#### Planning Application Queries

Planning Control (01495) 355555 or 355518

#### Listed Buildings

Heritage Officer (01495) 353313

#### Conservation Areas

Project Officer (01495) 353313

#### Tree Preservation Orders

Arboricultural Officer (01495 311556)

#### Building Regulations

Head of Building Control (01495) 355529

#### Protected Species

Ecologist (01495 311556)

#### Highways and Transportation

Tel: (01495) 355371

### General contacts

#### Planning Portal

<https://www.planningportal.gov.uk/permission/>

**Police Architectural Liaison Officer Community Safety**  
(01633) 247925

#### Natural Resource Wales

(0300) 0653000 – [naturalresourcewales.gov.uk](http://naturalresourcewales.gov.uk)

#### The Royal Society of Architects in Wales (RSAW)

(02920) 228987

#### Royal Town Planning Institute (RTPI)

(02079) 299494

#### Royal Institution of Chartered Surveyors

(02920) 224414

**Chartered Institute of Architectural Technologists (CIAT),** (02072) 782206

#### Architects Registration Board

<http://www.arb.org.uk/Home>

#### Landscape Institute

<http://www.landscapeinstitute.co.uk/>

#### Building for Life

[www.buildingforlife.org](http://www.buildingforlife.org)

#### CADW

(01443) 336000

#### Design Commission for Wales

<http://dcfw.org>

#### Energy Savings Trust:

(02920) 468340



## Further Reading

The following documents are available from the Welsh Assembly Government or Office of the Deputy Prime Minister (ODPM):

**Welsh Assembly Government 2014, Planning Policy Wales (edition 7)**

<http://gov.wales/topics/planning/policy/ppw/?lang=en>

**Welsh Assembly Government 2014, A Guide for Householder s**

<http://gov.wales/docs/desh/publications/140422householder-permitted-development-guide-en.pdf>

**Welsh Assembly Government 1996, TAN 7 Outdoor Advertisement Control**

<http://gov.wales/topics/planning/policy/tans/tan7/?lang=en>

**Welsh Assembly Government 2005, TAN 8 Renewable Energy**

<http://gov.wales/topics/planning/policy/tans/tan8/?lang=en>

**Welsh Assembly Government 2014, TAN 12 Design**

<http://gov.wales/topics/planning/policy/tans/tan12/?lang=en>

**Building Regulations Blaenau Gwent County Borough Council**

<http://www.blaenau-gwent.gov.uk/28.asp>

**Planning Permission - A Guide for Business**

<http://gov.wales/docs/desh/publications/060201ppguidebusinessen.pdf>

**A Householder's Planning Guide for the Installation of Antennas including Satellite Dishes**

<http://gov.wales/docs/desh/publications/141028planningantennasen.pdf>

**The Party Wall Etc Act 1996: explanatory booklet**

<https://www.gov.uk/party-wall-etc-act-1996-guidance>

**Protected Trees - A Guide to Tree Preservation Procedures**

[https://www.gov.uk/government/uploads/system/uploads/attachment\\_data/file/244528/2127793.pdf](https://www.gov.uk/government/uploads/system/uploads/attachment_data/file/244528/2127793.pdf)

**External Solid Wall Insulation: A Planning Guide for Householders**

<http://gov.wales/docs/desh/publications/131001external-solid-wall-insulation-guide-en.pdf>

**WAG 2009 – Generating Your Own Energy: A guide for householders, communities and businesses**

<http://gov.wales/docs/desh/publications/111121energy1en.pdf>

**WAG Improving you home - A Climate Change Guide**

<http://gov.wales/docs/desh/publications/090305planningclimateguideen.pdf>WAG

**Planning - A guide for householders. What you need to know about the planning system.**

<http://gov.wales/docs/desh/publications/051001hhguideenpdf>

# guidance notes



**Guidance Note 1: Extensions and conservatories**

**Guidance Note 2: Garages and outbuildings**

**Guidance Note 3: Dormer windows and rooflights**

**Guidance Note 4: Boundary treatments**

**Guidance Note 5: Trees and other vegetation**

**Guidance Note 6: Providing for access and parking**

**Guidance Note 7: Raised decks, retaining walls and balconies**

**Guidance Note 8: Resource efficiency**

**Guidance Note 9: Crime prevention**



# guidance note 1

## extensions and conservatories

An extension or conservatory is likely to be the most significant change you will want to make to your home. If poorly designed, it will negatively affect the appearance and value of your property, neighbours and the street scene.

### The size, position and shape of extensions and conservatories

Key principles when considering the size, position and shape of your extension are set out below. Front extensions (including conservatories) will not be acceptable except in exceptional circumstances. These circumstances might be that front extensions are already a characteristic feature of your street.

- The extension or conservatory must not dominate your house. As a general rule extensions and conservatories should be smaller than the house and positioned to the side or rear and set back from the principal elevation.

### Some examples of rear and side extensions

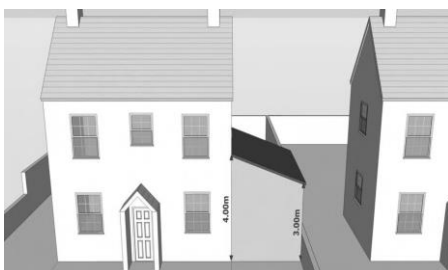
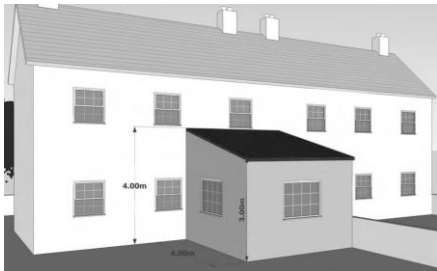

- All two and second storey extensions must have a pitched roof unless site and local conditions indicate that an alternative design solution would be acceptable. It is also recommended that single storey extensions have a mono or pitched roof, particularly where it will be visible from the wider streetscene.

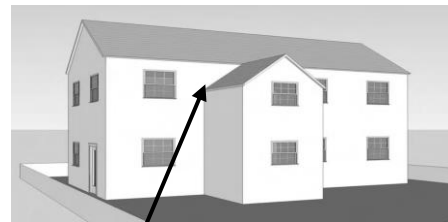

Lower ridge line and extension set back from front of house

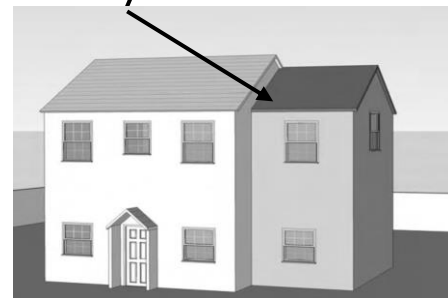

Extension set back from front of house

- Extensions must not exceed 4.5m in length at first floor level when measured from the main back wall of the original house. Ground floor extensions must not be excessive and must not impact on the amenities of neighbours especially in a terrace situation

Main back wall

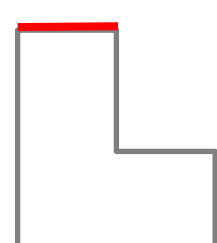
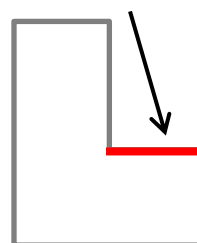

- For clarity, the main back wall of the house is taken to be the one supporting the main pitched roof and does not include a wing or any other extensions.

- In exceptional circumstances extensions that project more than 4.5m from the main back wall of the house may be considered acceptable subject to site specific circumstances e.g. separation distance to neighbours, size of the site, ground levels etc.
- Where possible the extension or conservatory should leave a reasonable space around the house for maintenance purposes and an adequate area of garden should remain for the amenity of existing / future residents.
- On corner plots, extensions or conservatories need to respect the street scene and have suitable boundary treatments.
- Sometimes neighbours can combine extensions to provide mutual benefits.
- It is important to consider how your extension or conservatory affects access and parking as set out in guidance note 7 of this document

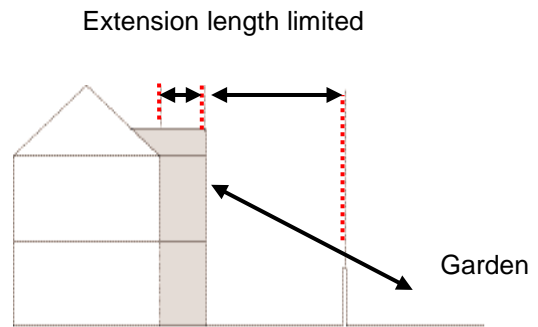

Overlooking of a neighbour's garden can be avoided by ensuring an adequate separation distance

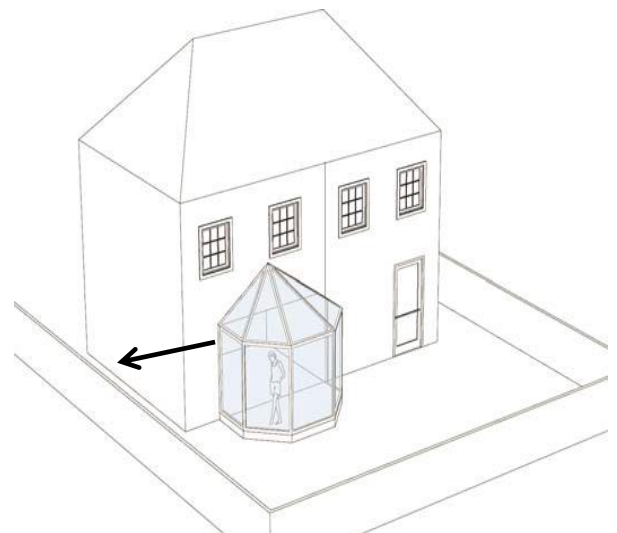

Conservatories should not overlook a neighbour's garden. This is particularly an issue where the conservatory is close to a neighbour's boundary or elevated, but the problem can often be overcome by screening with a tree or wall, or obscure glazing in the conservatory

### Privacy and overlooking

Extensions must avoid unacceptable overlooking of neighbouring houses or gardens. Habitable rooms such as bedrooms, living rooms, studies or kitchens-diners can cause issues of direct overlooking into neighbouring properties particularly where the extension is close to the boundary or in some instances a sloping site.

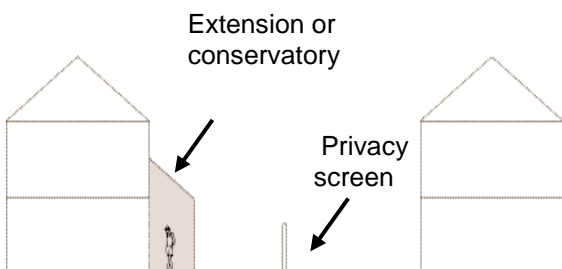

The erection of a wall or fence can provide a privacy screen between a single storey extension or conservatory and a neighbour's garden

### Avoiding 'overbearing'

Extensions and conservatories must not be overbearing to your neighbours. In most circumstances you will be required to restrict all first floor rear extensions to 4.5m in length as measured from the main back wall of the original house, not including any later additions or other structures. Ground floor extensions must not be excessive and must not impact on the amenities of neighbours especially in a terrace situation.



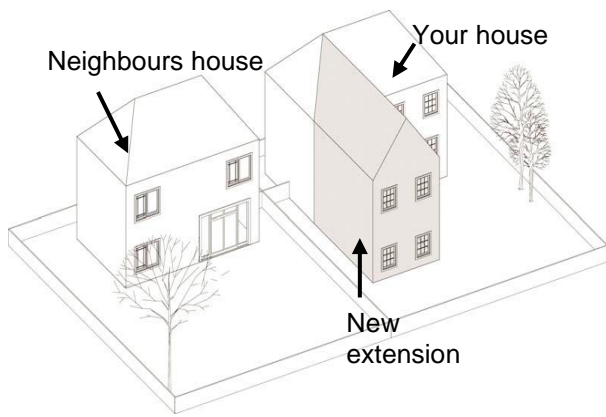

Large new extension with an overbearing impact on the adjacent more modest property

### Maintaining an adequate gap between adjacent properties

Side extensions and conservatories should leave an adequate gap with adjacent properties. This is particularly important for streets with detached or semi-detached houses where large side extensions and garages can fill the gaps and create the impression of a terrace. The Council refer to this as 'terracing effect' and it may be a legitimate reason to refuse planning permission.

Two storey side extensions should be sufficiently set back from the front of the property and have a lower roof ridge line than the house to avoid this terracing effect.

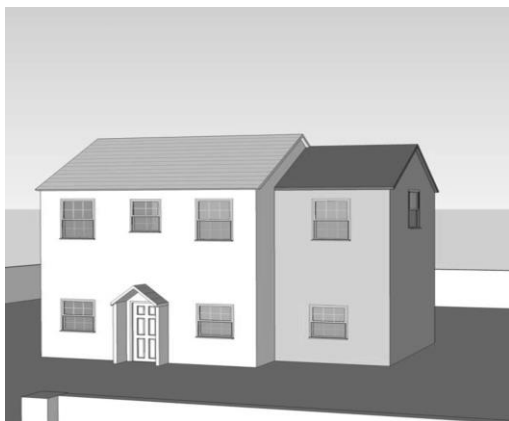

Side extension has been set back from the front of the house

### Using the right materials

You should avoid external materials that are not sympathetic to the existing property and the surrounding area. The materials that you use for your extension, garage or outbuilding should match or complement those used on your house.

Although it may not be possible to find matching materials, particularly for older houses, your proposals will be expected to use materials that complement the colours, tones and textures of your house.

### Windows and doors

Extensions should be designed to have windows and doors that are similar to the house in size, colour, shape, design and proportion. They should also reflect the pattern and arrangement of the windows of the house. The existing front door and main entrance to the house should be kept unless the Development Management Team advises you that an alternative entrance into the extension may be acceptable.

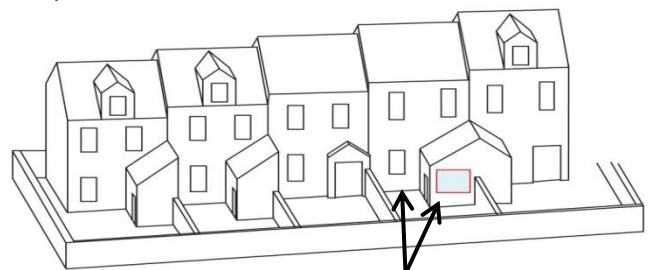

Poor example where extension window has a different shape and proportion to those of the main house

### Architectural style

As a general rule, the architectural style of your extension should be the same as your existing house and reflect the characteristics of the locality. If you think a more contemporary or innovative approach to the design might be appropriate, you should discuss this with the Council at an early stage. In either case the Council will want to be sure your proposals will contribute to the quality of the locality.

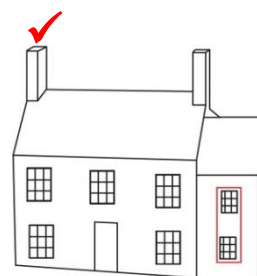

Side extensions: windows of similar proportions



Side extension: windows of wrong proportion

# guidance note 2

## garages and outbuildings

Key principles when considering the size, shape and position of your new garage or outbuilding are:

- Garages and outbuildings should be designed to take into account loss of access, amenity space and parking as set out in Guidance Note 6 in this document.
- Where possible, development should not result in the loss of trees or other features that are important to the area.
- An outbuilding must be smaller in scale and subservient to the house.

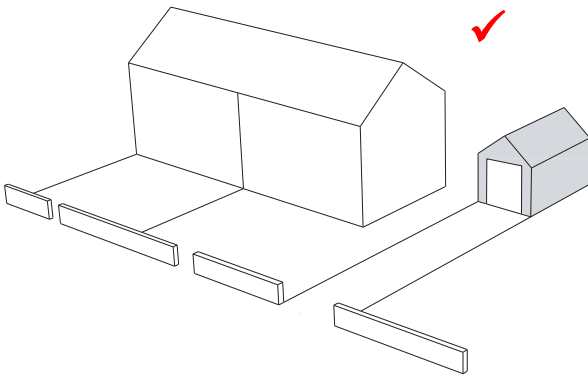

**Building of similar proportions to house and set back from front**

- Garages and outbuildings should not be forward of the front building line unless they are a feature of the streetscape.

- Garages and outbuildings must not be over dominant in relation to the existing and surrounding properties.

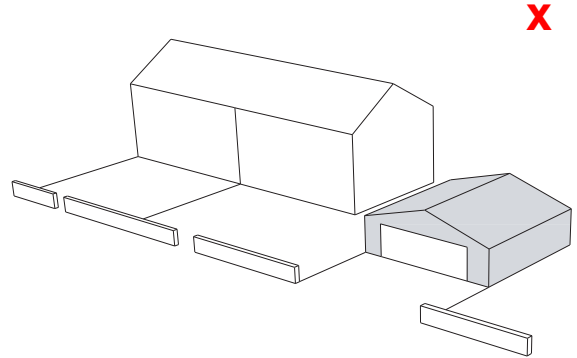

**Low pitched over large building set forward of house with wide doors**

- Pitched roofs are recommended as long as this does not unacceptably increase the massing of the building.
- The materials you use for your garage should complement those of your house, this includes the use of tile, slate or tiled sheets on roof area.
- Garage doors should be as narrow as practical with two single garage doors preferred over one double door.
- Doors should be powder coated and not plain galvanised or metal finished.

(also refer to Guidance Note 6)

# guidance note 3

## dormer windows and roof-lights

Dormer windows are discouraged on the front roof of your house, unless they are a characteristic local feature. Sloping (flush fitting or Velux) roof lights are less intrusive than dormer windows and can reduce problems of overlooking.

Increasing the roof height of a dwelling by altering the eaves height or pitch can be difficult and expensive to achieve satisfactorily and will not be acceptable in a terrace or a street in which heights and roof pitches are the same or adopt a uniform step to account for level changes.

### Key principles:

- Flat roof dormers will not be acceptable unless they are a characteristic feature of the area.
  - Dormer windows should use the same pitch and roofing details as the main roof.
- ✓ **Small pitched dormer set well back from eaves, down from ridge and in from sides**

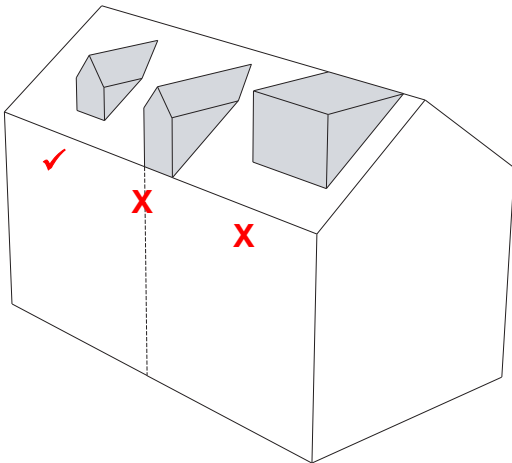

**X Dormer face at eaves ridge too high and too close to party wall**

- Dormer windows should cover no more than 50% of the roof area on which it is located. In some cases this may not be appropriate and smaller dormers will be required.

- Dormer windows must be set well back from the eaves, down from the ridge and in from the sides of the roof
- New dormer windows should reflect the design of dormer windows that are an original feature of other buildings in your area or street.

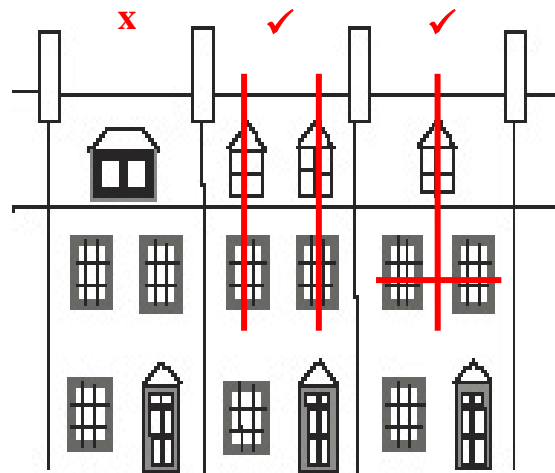

**Note the symmetry and size of the windows above. Often two small dormers are better than one large dormer**

- Dormer windows should be positioned to match the pattern of the windows on the rest of your house.
- Two smaller dormer windows are usually better than one large window.

- Rooflights should ideally be set within the middle third of the roof slope away from gables or roof abutments and chimneys.

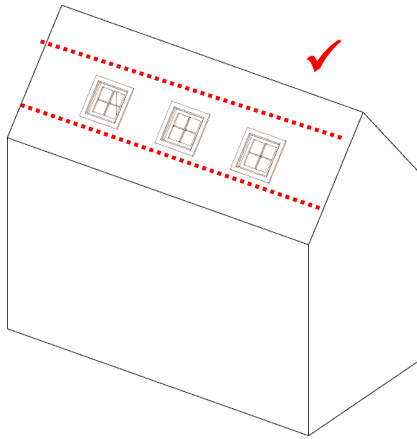

small rooflights in the middle third of the roof space and evenly spaced

- If there is more than one roof light they should be at the same level, evenly spaced, and of the same size, shape and design.

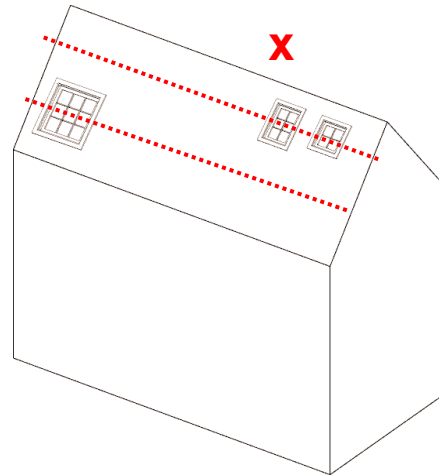

rooflights too large and too close to eaves and verge. A variety of sizes, spacing and levels



# guidance note 4

## boundary treatments

Boundaries between plots and those that are forward of the front elevation are important visual elements of residential development that not only make a significant contribution to the quality of development and add to security, but, can also add to the ecological value of the development. Boundaries may include walls (brick or natural stone), railings, gates, timber fencing and hedgerows. Hedgerows provide natural cover for nesting birds, but other elements can include simple design features which provide niches for a whole range of species that serve to enhance biodiversity value.

### Key principles:

- Front boundary treatments should complement height, materials and the type of properties on either side. This is particularly important where they are generally the same along the rest of the street.



consistent frontage treatments contribute to the character of your street and should be retained



Consistent frontage treatment

- New front boundary treatments must not obstruct views of the house from the

street, or prevent surveillance of the street from the house. Applications for high boundary enclosures on frontages of properties are likely to be refused.

- In the interest of highway safety new boundary treatments must not restrict visibility splay of existing driveways roadway junctions
- When considering boundary treatments for corner plots, be aware that the height needs to be carefully considered. Ideally it should be in line with the primary elevation height. Long, high, blank boundaries will result in a deadening effect on the street scene and will not normally be allowed.
- Hedging can have an attractive effect and has biodiversity value, but will need to be maintained by regular pruning to stop over growth. Fast growing conifers should be avoided due to overshadowing and they are high maintenance.



Use of hedging to form part of boundary

- Close boarded timber fencing is rarely acceptable on boundaries that directly face the pavement or road to the front of your house.
- Colour finishes and detailing of boundaries (timber, brick, stone) need to be carefully considered to ensure they complement the overall setting.

# guidance note 5

## trees and other vegetation

Existing trees and planting help make areas more attractive and add to the value of your home. However it is easy to damage trees and planting when carrying out works either by affecting the soil around the root zone or by cutting roots in the construction of services and foundations. This type of work may render a tree unsafe and cause a future hazard to people or property.

- Building works should not be carried out underneath tree canopies or within a two metre radius of smaller trees with an undeveloped crown.
- Excavation and construction should not take place within two metres of the centre of boundary hedges to be retained and within four metres of the centre of native species boundary hedgerows to be retained.
- Equipment or materials should not be stored underneath tree canopies or within a two metre radius of smaller trees with an undeveloped crown.
- Some trees are protected by law by Tree Preservation Orders. It is illegal to carry out work on, or remove these trees without permission. If in doubt check with the Council (01495 311556) whether any of the trees on your property are protected by Tree Preservation Orders.
- If your property is within a Conservation Area e.g. central Tredegar, you must check with the Council before carrying out any work that might affect any trees as these are also protected by law.

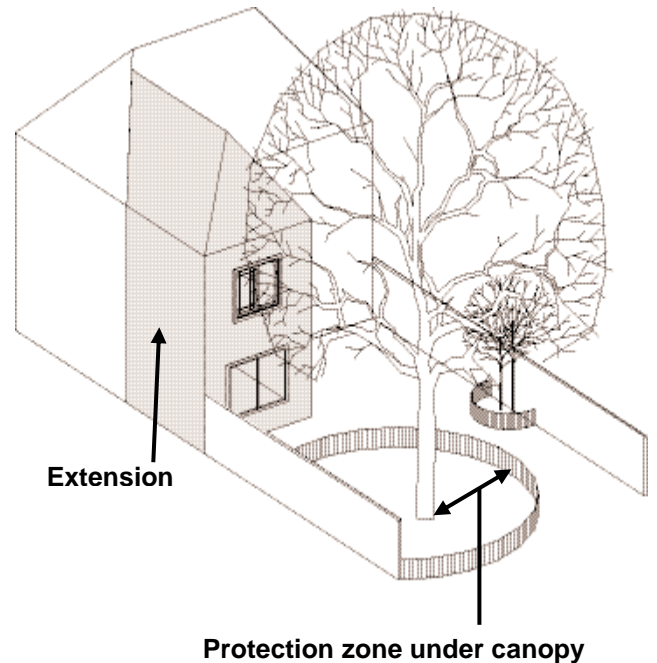

**The roots of large trees generally need to be protected within an area that corresponds with the canopy above. Within this zone building materials should not be stored and roots should not be severed**

# guidance note 6

## providing for access and parking

You must obtain separate approval from the highways department of the Council if your proposed extension or alteration will result in changes to your vehicular access, more or less parking spaces, a new driveway, a new crossing to the pavement or verge or if a new dropped kerb is required. You will also need to apply for planning permission if you want to make a new or wider access for your driveway on to a trunk or other classified road. The highways department of the Council can tell you if the road falls into this category. Planning permission may also be required to widen or create a new access subject to the type of hard surface used and water run-off.

### Key principles:

- Maintain existing off street parking spaces and comply with the adopted guidelines: (see "Access Car Parking and Design – Supplementary Planning Guidance via the following link:- <http://www.blaenau-gwent.gov.uk/business/7727.asp>)
- Check with the Council whether your extension may call for additional parking spaces. This may be the case if it includes additional bedrooms.
- The access must be safe with adequate visibility. The highways department will advise on their safety standards and how to meet them.
- Gates will not be allowed to open outwards onto the pavement or highway.
- In some instances where it is practical to do so, access off a main highway may require a turning area within your land so vehicles do not have to reverse in or out onto the public highway.
- Parking spaces should normally measure 4.8m by 2.6m or larger for disabled access (4.8m by 3.6m). Within a garage the normal parking space should be increased to a width of 3m to allow car

doors to be opened and the minimum recommended internal length is 6m.

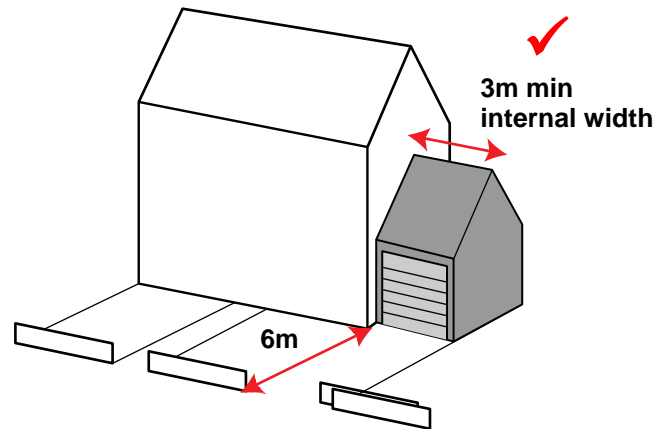

If practicable a garage door should be a minimum of 6m back from the front boundary to allow a parked vehicle in front

- Drives should be at least 3.2m wide to provide access for pedestrians and parking. Length of the drive should be 6m (refer to Guidance Note 2 on Garages).
- Any new garage must not have a detrimental impact on the safety of users of the highway and may be required to be set back to achieve safe vision splays.

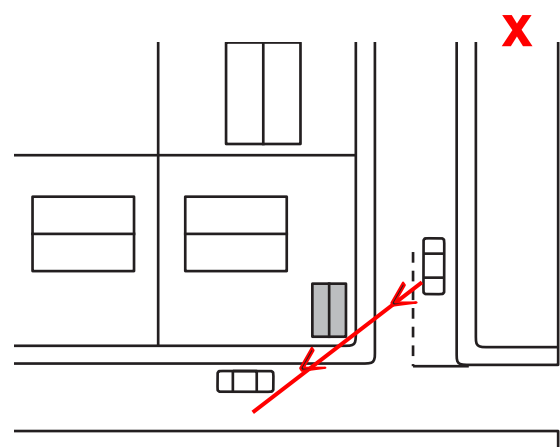

Garage / outbuilding too close to corner for visibility, in front of building line and with insufficient drive

# guidance note 7

## raised decks, balconies and retaining walls

### Decking

When considering decking, have regard to the impact on your neighbour. Decking can enhance the use of your garden, but it must not by virtue of its size or position adversely affect your neighbour's amenity or privacy or impact visually on the amenities of the wider area. All decking over 30cm in height (as measured from ground level) and/or more than 50 percent of garden area will require planning permission. Building Regulations may also be required for Deck Structures depending on their location, position and intended use.

### Key principles:

- Consider the siting of your decking. Sited too close to the boundary, the decking may result in overlooking of your neighbour's property which would not be acceptable.
- Ensure that the design of the decking compliments the character of your house. The scale, massing and materials used in the decking should respect the appearance of your property, neighbouring properties and the overall street scene.



Respects the appearance of the property (Source: Google images)

- Decking is often elevated above ground to compensate for the slope of a site. If the decking is elevated, the impact of the structure and safety fencing could

increase the overbearing impact, cause overlooking of neighbouring properties and in some cases, cause overshadowing. Furthermore the height of a fence erected on a decked area may in itself require planning permission.



Sympathetic fencing (Source: Google images)

### Balconies

In most cases verandas and balconies will require planning permission.

A balcony should respect the character and appearance of your house. It must not unbalance or dominate the elevation to which it is attached or the appearance of the house when viewed from the street. Depending on their size and the room they serve balconies can provide additional amenity space to the property but at the same time result in overlooking and noise generation. Rear balconies can be particularly difficult in this respect because of their relationship with the private rear gardens of neighbouring properties.

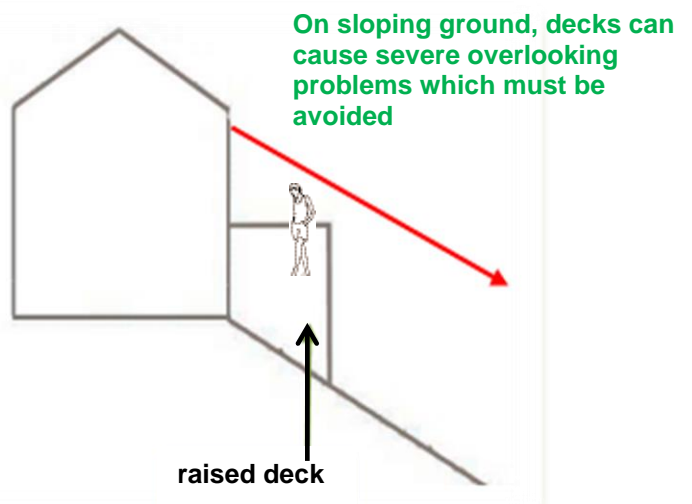



- A veranda is usually defined as a gallery, platform, or balcony, usually roofed and often partly enclosed, extending along the outside of a building at ground level.
- A balcony is defined as a platform with a rail, balustrade or parapet projecting outside an upper storey of a building.

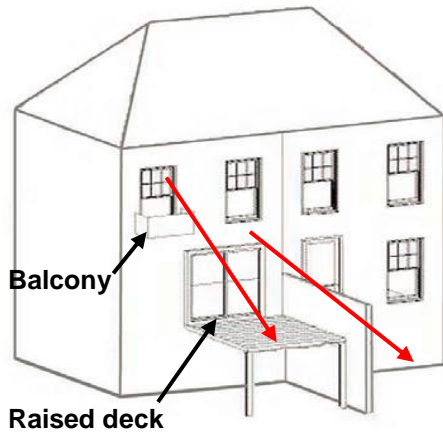

**Potential overlooking from balconies and decking should be avoided**

## **Retaining walls**

New or replacement retaining walls should respect the character of the area and not impact upon the amenity of neighbours.

- The overall height of a retaining wall plus any fencing/railings on top will need to be taken into account as they can dominate the street scene.
- Where any new retaining wall or structure is over 1.5m high, you will need to apply for Planning Permission and will require structural calculations.
- Use finishes that are in keeping and are appropriate to the area i.e. if replacing a stone wall, keep the stone as it can be used to face your replacement wall.
- Consider if it is possible to grow plants in front of your retaining wall in order to provide visual softening.



# guidance note 8

## resource efficiency

Resource efficiency means minimising the energy your house needs for heating, lighting and other energy uses. It also means using materials and construction methods that do not require a lot of energy to either produce or build.

Proposals for alterations and extensions which achieve high levels of resource efficiency are encouraged.

### Key principles:

- Use high levels of insulation. In general 250mm of loft insulation and around 100mm of cavity wall insulation and 100mm of insulation under a solid ground floor is recommended. Where external wall insulation protrudes over the public highway, approval will be required by the Highway Authority (irrespective of permitted development rights).
- Glazing should be sealed double glazing with a 12mm air space and 'low E glass' to reduce heat loss.
- Wherever possible use materials that are produced locally and which come from a source that can be renewed without harm to the environment. High quality reclaimed materials can save resources and may also provide a better match with the existing building.
- Avoid the use of tropical hardwood and source timber which is certified as coming from sustainable sources.



Energy efficient eco-house

- In designing your alteration or extension consider whether there are opportunities to build-in features to produce energy. This may include solar panels or domestic wind turbines. Solar water heating panels can provide 50% of your hot water requirements, while photovoltaic panels and wind turbines can produce some of your electricity. Whilst energy saving features are encouraged, if poorly located they can detract from the character of your house or neighbourhood, especially if the building is listed or within a sensitive area such as a Conservation Area. If you are planning to incorporate any of these features you should check whether they need planning permission.



Energy efficient eco-house (Source: Google images)

- You can also save energy and heat your home by making the most of the heat from the sun, especially if your extension faces southeast to southwest. Generally windows on the south side of the building should be larger than those on the north side.
- Arrange the internal layout of your new or altered extension so that the main habitable rooms are on the southerly side of the building where this does not cause overlooking problems.



**Energy efficient eco-house**

- In the summer you can avoid the need for cooling or air conditioning by ensuring that south facing windows are shaded, e.g. by roof overhangs or trees or reflective blinds.
- Although conservatories can provide an additional light room in the winter months they can be very expensive to heat in the winter and can waste energy. Conservatories should be separated from the main house by an insulated wall and closable doors and windows so that you can avoid having to heat it when it is cold.
- In very heavy rain, water run-off from hard surfacing can overwhelm drains and cause flooding and pollution. You can reduce this by using a 'green' roof, which has turf or plants sitting on a waterproof membrane and should have a low pitch of less than 15 degrees. Permeable paving surfaces such as blocks or bricks set in the ground would be a requirement on replacement hard surfaces forward of the front building line of the house and would allow rain water to drain away gradually. Rainwater butts can provide a useful source of water for garden watering or car washing in drier periods.
- If your proposals involve demolition, re-use as much of the demolition waste as possible on-site.
- Provide house entrances away from prevailing winds and protect with a porch or lobby.

- Contacts for information on renewable energy are given at the end of this document.

### **External wall insulation**

Planning permission is not normally required for fitting external wall insulation providing that;

- It does not project from the house by more than 16cm and does not necessitate alterations to the existing structure of the dwelling.
- It is not within a Conservation Area; if it is then you will need to contact the Planning Department.
- Insulation has to comply to the relevant building regulations, when installed, during construction, or when fitted retrospectively.

# guidance note 9

## crime prevention

The Council encourages design that reduces crime under section 17 of the Crime and Disorder Act. Whilst carrying out works to your property you would benefit from considering your property's security. The Council supports 'Secured by Design' which is a scheme operated by the Police. More details of this can be found at [www.securedbydesign.com](http://www.securedbydesign.com). What can you do to make your home more secure?

- If a burglar or thief think they can be seen they are less likely to commit a crime so provide good natural surveillance from your home onto the street, your gardens and driveways. This can be achieved by the careful positioning of windows.
- Where possible ensure that you can view your parking area from your house.
- Low boundaries at the front give maximum visibility but high walls and fences of 1.8m provide good security at the rear whilst side entrances should be lockable.

- Dusk to dawn operated lighting surrounding your property will deter burglars (but make sure that it is positioned so that it is not a nuisance to your neighbours).
- Consider fitting a good quality burglar alarm, a proven deterrent.
- You should ensure that all locks are securely fitted and meet British Security Standards. You will find the information you need at the following web address:

<http://www.securedbydesign.com/professionals/doorslocks.aspx>

The Home office has published the following documents; "A guide to home security" and "An introduction to domestic surveying". These can be obtained via the following links:

<http://webarchive.nationalarchives.gov.uk/+http://www.homeoffice.gov.uk/crime-victims/reducing-crime/burglary/>

<http://webarchive.nationalarchives.gov.uk/20080901210549/crimereduction.homeoffice.gov.uk/burglary/burglary46.htm>

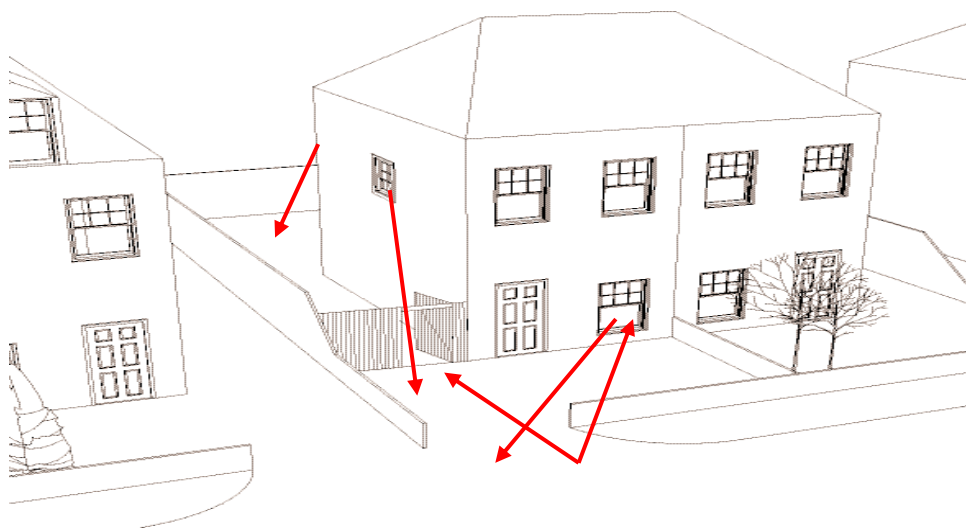

**Key security considerations: reducing visibility of rear garden from street, surveillance of drive and street, clear views to street frontage, secure rear fence**